

TZOA



Haven

Home Air Monitor

Background & tech specs

Introducing Haven



BACKGROUND

We breathe in and out roughly 20,000 times per day, a subconscious behaviour that we often forget about. Exhaled carbon dioxide, as well as dust and chemicals recirculating around our homes can build up to levels that stress our immune systems and greatly affect our health and productivity.

WHAT CAN HAVEN DO?

Haven's sensors continuously monitor key factors of our Indoor Air Quality (IAQ). These can pinpoint problem areas in the HVAC system, such as a lack of ventilation and filtration, high humidity or low airflow.

HOW DOES IT WORK?

After purchasing Haven, a local trusted HVAC service technician installs it in the home's heating, ventilation and air conditioning (HVAC) system. This is commonly known as a central or forced air system. The complete installation process takes less than one hour.

By being positioned in the return duct, in front of the furnace and air filter, Haven is able to detect air pollution and other environmental factors that travel through the entire home.

These factors include volatile organic compounds (VOCs), harmful micro particles (commonly known as PM2.5), as well as humidity, airflow velocity, temperature and pressure. These can all contribute to allergies, asthma, and other medical conditions or general irritations like itchy eyes and throat.

Tech Specs

REQUIREMENTS

INSTALLATION

Suitable for any duct (round and rectangular) minimum 8" wide

Min. 24" away from airflow obstructions (eg. duct bends)

Probe must be perpendicular to airflow; preferably installed with air flowing from A to T of logo on mounting plate

Angle of device relative to airflow needs to be $< 10^\circ$

CONNECTIVITY

WiFi: 802.11 b/g/n

Connectivity: WPA / Open

Communication interval: 1x every 5 minutes

DATA ACCESS

Haven Home app: live data updates, with daily and weekly overviews; available for iOS and Android

POWER

Wired: 24V AC; 14–22AWG

Peak current consumption: 0.08A

Average current consumption: 0.06A

Peak power consumption: 2W

OPERATING CONDITIONS

Temperature: -5 – 50°C / 23 – 122°F

Humidity: 0–95% non-condensing

DETECTION

PARTICLES

Technology: Laser light scattering

Range: 0.3 – $10\mu\text{m}$

Reporting format: PM2.5, PM10

Concentration: $1\mu\text{g}/\text{m}^3$ to $> 250\mu\text{g}/\text{m}^3$

Units: number concentration of particles ($\#/ \text{cm}^3$) and equivalent mass concentration ($\mu\text{g}/\text{m}^3$)

Accuracy: 80% ($*R^2$ compared to reference instrument readings)

CHEMICALS (tVOC)

Range: 10–1200ppb

Units: parts per billion (ppb) and mass concentration ($\mu\text{g}/\text{m}^3$)

TEMPERATURE

Range: 0 – 50°C / 32 – 122°F

Precision: $\pm 1^\circ\text{C}$ / 1.8°F

RELATIVE HUMIDITY

Range: 5–95%

Precision: $\pm 3\%$

AIRFLOW VELOCITY

Range: 0–6m/s

Resolution: 0.1m/s

Precision: $\pm 5\%$

PRESSURE

Range: 80–120kPa

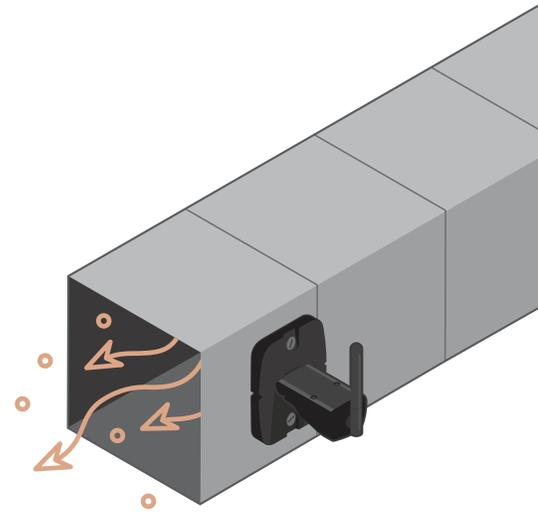

Design

APPEARANCE

MATERIAL

Glossy PC ABS plastic housing;
copper stamped emboss and laser
etched artwork

MOUNTING PLATE

Dims: 2.6" x 3.3" x 0.6"

Weight: 26g / 0.9oz

PROBE

Dims: 8.6" x 1.2" x 0.9"

Weight: 71g / 2.45oz

Sensor Life: 5+ years

INTERACTIONS

LED SIGNALS

Blue: Waiting for configuration in AP mode (hard reset state).

Blue flashing: Attempting to connect to WiFi (SSID) after credentials have been submitted.

Green flashing: Connected to WiFi network but not to the cloud. If persists without changing to solid color, home's WiFi network firewall may be blocking Haven's access to Cloud.

Green: Functioning & transmitting telemetry to the cloud. LED will flash aqua when it sends data to the cloud (minimum every 60 seconds).

Green/purple flashing: Haven is not positioned correctly. Make sure probe is clicked into the mounting plate.

Orange: WiFi credentials are incorrect, have changed or WiFi is unavailable. Haven is re-entering AP mode and is ready to connect to WiFi again.

SOFTWARE

HAVEN INSTALLER APP

Available for iOS and Android.

Guides professional contractors and service technicians through installation of Haven and connecting it to home's WiFi network.

Provides troubleshooting.

HAVEN HOME APP

Available for iOS and Android.

Allows homeowners to monitor, control, maintain and improve their air quality.

Notifies user when there are abnormal filtration and ventilation events.

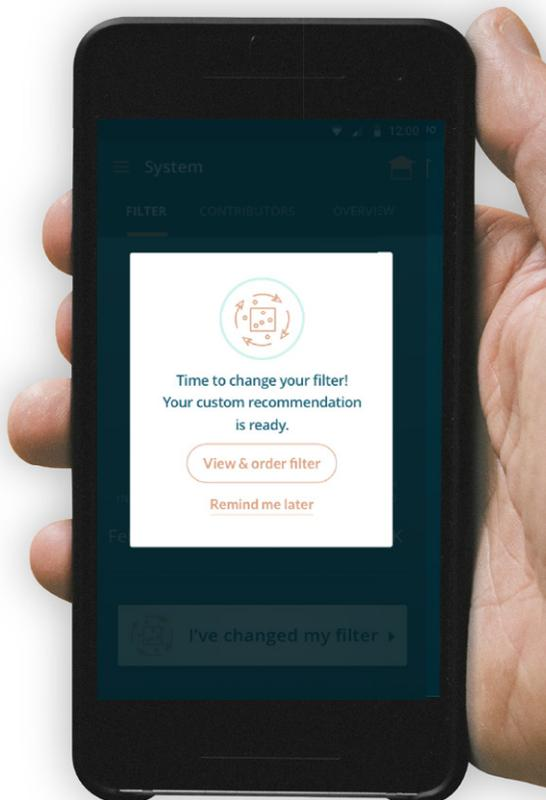



PRODUCT PACKAGING

PROBE & MOUNTING PLATE



DUCT-MOUNTED



HOME APP

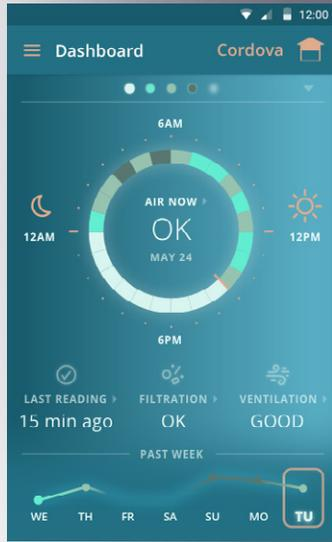

INSTALLER APP

